

UVO-CLEANER⁷

MODEL 342

INSTRUCTION MANUAL

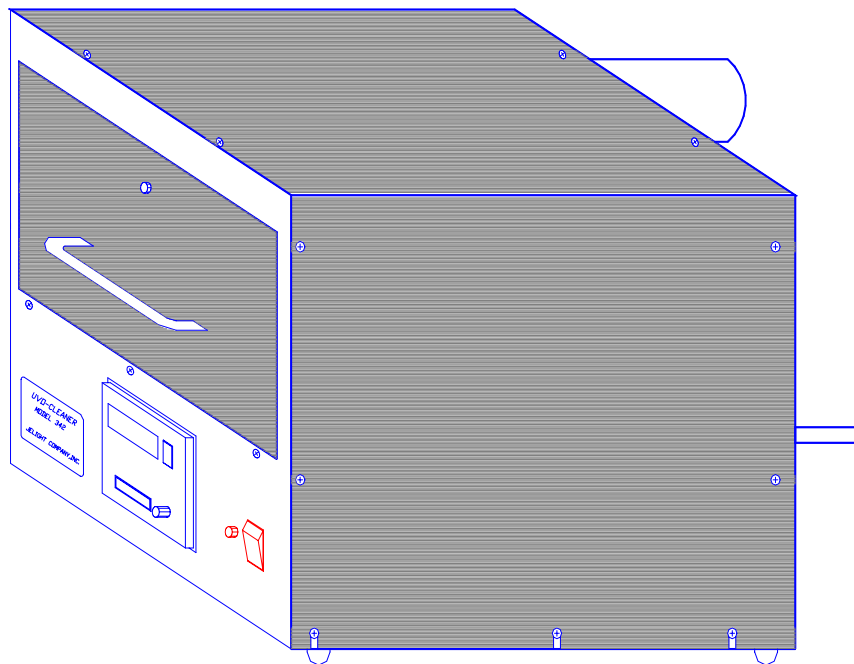

JELIGHT COMPANY, INC.

2 MASON

IRVINE, CA 92618 U.S.A.

Tel.: (949)380-8774 Fax: (949)768-9457

UVO-CLEANER⁷

MODEL 342

TABLE OF CONTENTS

Introduction	Page 2
Description & Assembly	Page 3
Operation	Page 5
Maintenance	Page 6
Trouble Shooting	Page 7
Specifications	Page 8
Schematic	Page 9

INTRODUCTION

The UVO-CLEANER⁷, Model 342 with 6.5" x 6.5" tray capacity is a very rugged unit designed to provide many years of trouble free service. The Model 342 relies on UV and ozone to remove organic substances from the surfaces of items processed in the unit. An example is quartz, which is substantially transparent to UV. Due to the transparency, both sides may be cleaned simultaneously.

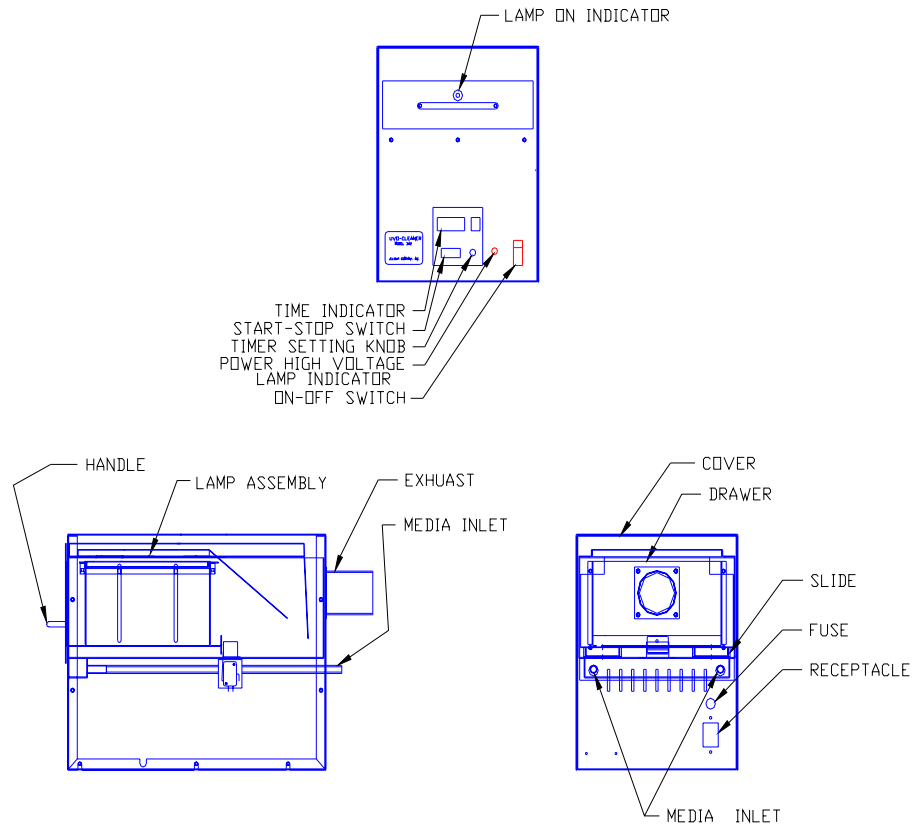

WARNING:

Potentially fatal voltages exist within this machine. Never remove the cover while the unit is plugged in to an electrical outlet.

This unit produces ozone; thus, appropriate ventilation must be provided for the exhaust. Immediately deactivate the unit if ozone is detected outside the unit.

The lamp in this unit emits harmful UV radiation; under no circumstances is exposure permissible. Qualified personnel must do servicing.

DESCRIPTION & ASSEMBLY

The UVO-CLEANER⁷, Model 342 is equipped with a stainless steel cover, stainless steel drawer & base, and adjustable stainless steel cleaning tray.

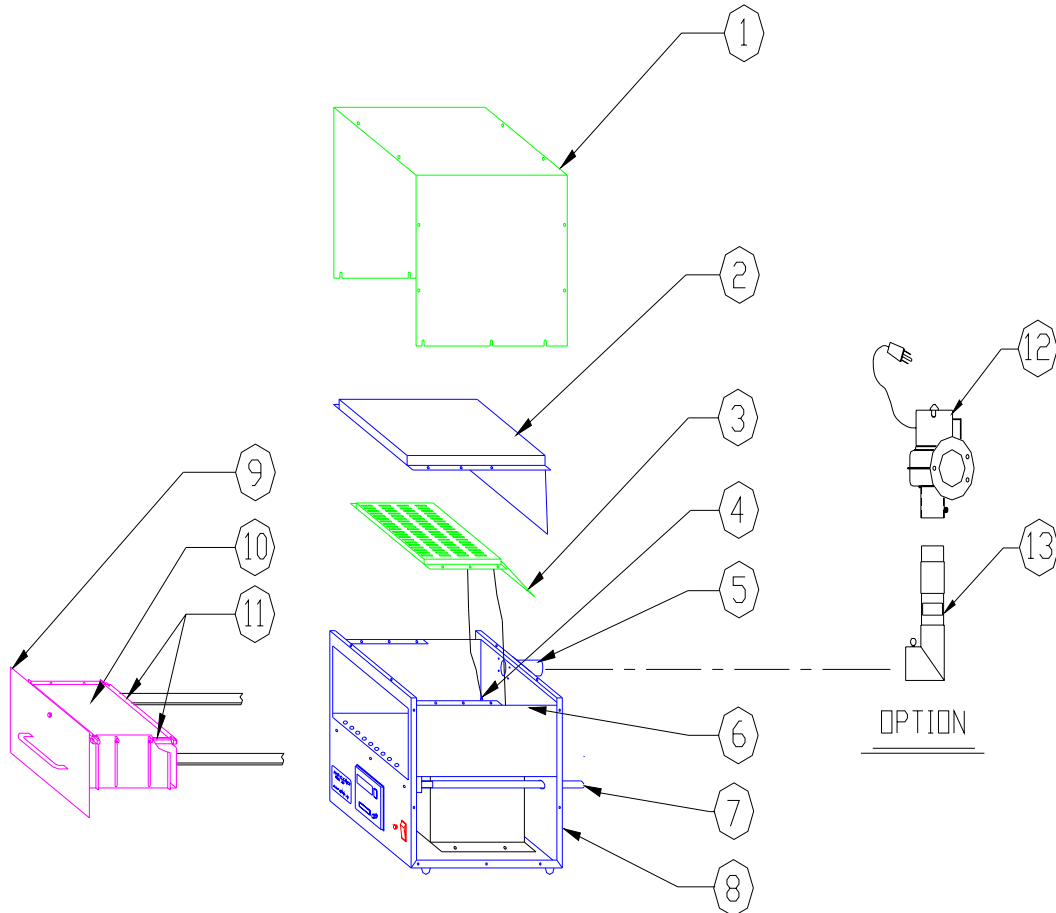

- | | | | |
|----|-------------------------|----|-------------------|
| 1 | Cover | 2 | Lamp Cover |
| 3 | Lamp Assembly | 4 | Ceramic Feed-thru |
| 5 | Exhaust Port | 6 | Shelf |
| 7 | Media Inlet | 8 | Base |
| 9 | Drawer | 10 | Tray |
| 11 | Carrier Guides | 12 | Blower (optional) |
| 13 | Ozone Killer (optional) | | |

DESCRIPTION & ASSEMBLY (Cont.)

To put the unit together, lay the lamp assembly (#3) next to the body assembly (#8), lamp side DOWN.

Connect the lamp wires to the ceramic feed-thru (#4).

Carefully place the lamp assembly, lamp side DOWN, on top of the shelf (#6).

Place the lamp cover (#2) on top of the lamp assembly. Screw both the lamp assembly and the cover to the shelf using the #8-32 x .30 long Phillips head screws provided.

While pushing the interlock switch in, place the cover on the unit. Secure the cover with the #8-32 screws.

Be sure to remove the vinyl caps from the two media inlet tubes at the rear of the machine.

OPERATION

To operate the UVO-CLEANER⁷, Model 342, first install the lamp assembly. Refer to Description & Assembly on Page 4. Once the main power cord is plugged into an electrical outlet, the main power switch can be turned on. The switch will light indicating power to the unit.

The exhaust of the Model 342 must be attached to a suitable exhaust system capable of maintaining minus 1/2 to 2 inches of water static pressure while in operation. It is recommended that a flexible metal 2-inch duct be used to attach this unit to your exhaust system; a 2-inch PVC pipe may be substituted.

Next, load the substrate onto the removable cleaning tray. The parts must be pre-cleaned since removing large amounts of contamination will take longer periods. Normal cleaning times should be determined through experimentation.

Adjust the side thumbscrews on the drawer to the appropriate settings for the desired height. The actual height of the tray varies according to the height of the product being cleaned. For optimum results, the surface of the parts being cleaned should be placed approximately 5mm away from the bottom of the lamp.

Once the drawer is shut completely, the safety interlock switch engages. If either the drawer or the cover is removed, the safety interlock mechanism automatically shuts off the UV light. Thus, accidental exposure to harmful UV radiation is prevented.

To set the cleaning time, turn the knob to the right of the display until the desired time is shown. Push the start/stop button to activate the timer. The power indicator will light acknowledging that the lamp is receiving power, and the UV light is operating.

A clock built into the timer may be set by holding down the button with clock graphics, while turning the knob to the right of the display. It is functional at all times when the unit is plugged in. To display the time, when the timer is not in use, press the clock button.

When the cleaning cycle is complete, the timer will sound an audible alarm and automatically extinguish the UV lamp. The drawer can then be opened, the tray removed, and the parts unloaded.

MAINTENANCE

The maintenance of the UVO-CLEANER⁷, Model 342 requires the user to remove and clean the lamp assembly once every 100 hours of operation. Every 5,000 to 10,000 hours of operation, the lamp assembly must be removed and replaced.

To remove the lamp assembly, disconnect the main power cord first. Remove the screws retaining the cover, and carefully lift it off. Next, loosen and remove the top nut on the ceramic feed-thru. Remove the lamp connectors from the feed-thru. Carefully lift the lamp assembly out, using caution not to break off the electrodes.

To install the new lamp assembly, disconnect the main power cord first. Remove the screws retaining the cover, and carefully lift it off. Next, loosen and remove the top nut on the ceramic feed-thru. Install the lamp over the holders on the shelf using the provided screws. Tighten the screws to ensure the lamp assembly is in place. Attach the lamp connector to the appropriate feed-thru. Replace the machine cover and be sure the interlock switch is inside the cover and tighten all the screws.

To change an old lamp, follow the above directions carefully.

WARNING:

USE EXTREME CAUTION WHEN CHANGING LAMPS. BE SURE THE PLUG IS OUT OF THE UNIT AT ALL TIMES WHEN THE COVER IS OFF. NEVER LOOK DIRECTLY INTO THE LAMP WHEN IT IS BURNING. BE VERY CAUTIOUS NOT TO BREAK THE LAMP DURING LAMP INSTALLATION OR REMOVAL.

TROUBLE SHOOTING

SYMPTOM: No Power To The Unit.

Check the power receptacle.
Check the fuse.
Check the cover & drawer interlock mechanism.

SYMPTOM: Power To The Unit/Timer Does Not Function.

Check the power source.
Check the drawer interlock mechanism.

SYMPTOM: UV Indicator Does Not Light.

Check lamp power indicator.
Replace the UV lamp assembly.
If this does not solve the problem, contact JELIGHT.

SYMPTOM: Ozone Is Present Outside The Unit During Operation.

Check the exhaust connections.
Check the exhaust the unit is attached to.

SPECIFICATIONS

Size (Max)	8.70"W x 18.00"L x 11.00"H
Power Requirements:	110Volts, 60Hz., 3Amps.
Lamp Type:	Low Pressure Mercury Vapor Grid
Lamp Output:	28,000 Micro watts per cm ⁵ @254Nm (From 6mm Dist.)
Tray Size:	6.5" x 6.5" cleaning area

