

UVO-CLEANER⁷

MODEL 288

INSTRUCTION MANUAL

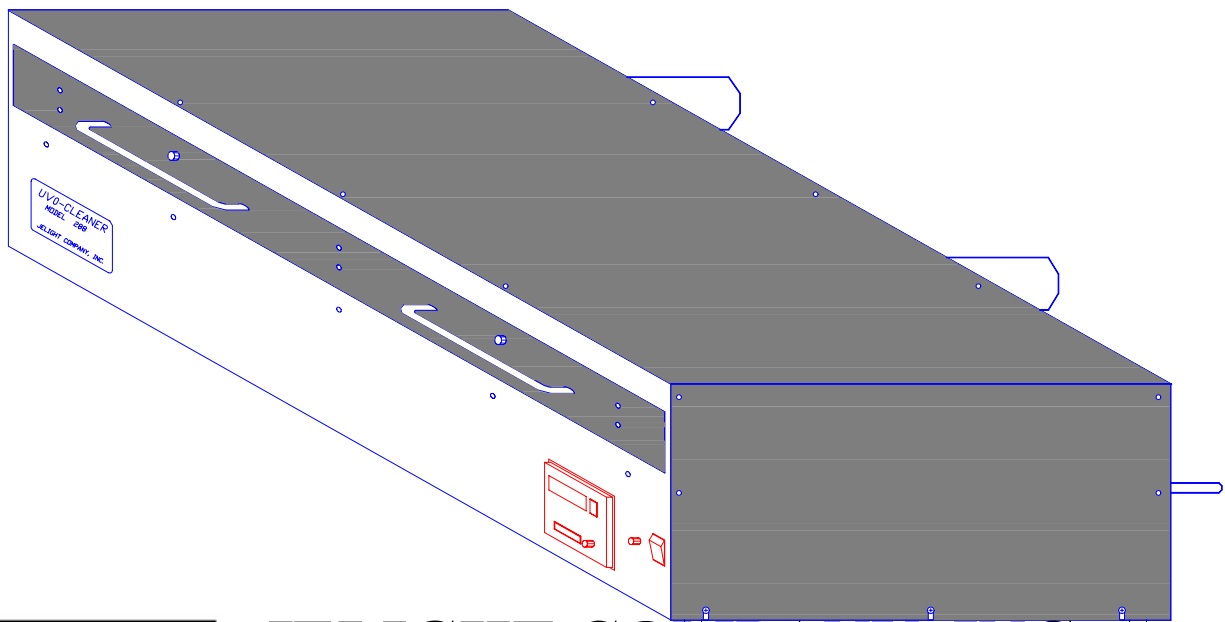

JELIGHT COMPANY, INC.

2 Mason

Irvine, CA 92618 U.S.A.

Tel: (949)380-8774 Fax: (949)768-9457

E-mail: sales@jelight.com

UVO-CLEANER⁷

MODEL 288

TABLE OF CONTENTS

Introduction	Page 2
Description & Assembly	Page 3
Operation	Page 5
Maintenance	Page 6
Trouble Shooting	Page 7
Specifications	Page 8
Schematic	Page 9

INTRODUCTION

The UVO-CLEANER, Model 288 with 12" x 24" tray capacity produces near-atomically clean surfaces in less than one minute by utilizing the UV/Ozone cleaning method. This process effectively and thoroughly removes an assortment of organic contaminants from surfaces. These contaminants include human skin oils, silicone oils, solder flux, residues from wet cleaning processes or water residue, contamination absorbed during prolonged exposure to air, and many others.

For optimum results, the surfaces of the samples must be precleaned to remove contaminants such as dust and inorganic salts, which cannot be changed into volatile products by oxidation. To maximize the cleaning rate, samples should be placed as close to the UV source as possible.

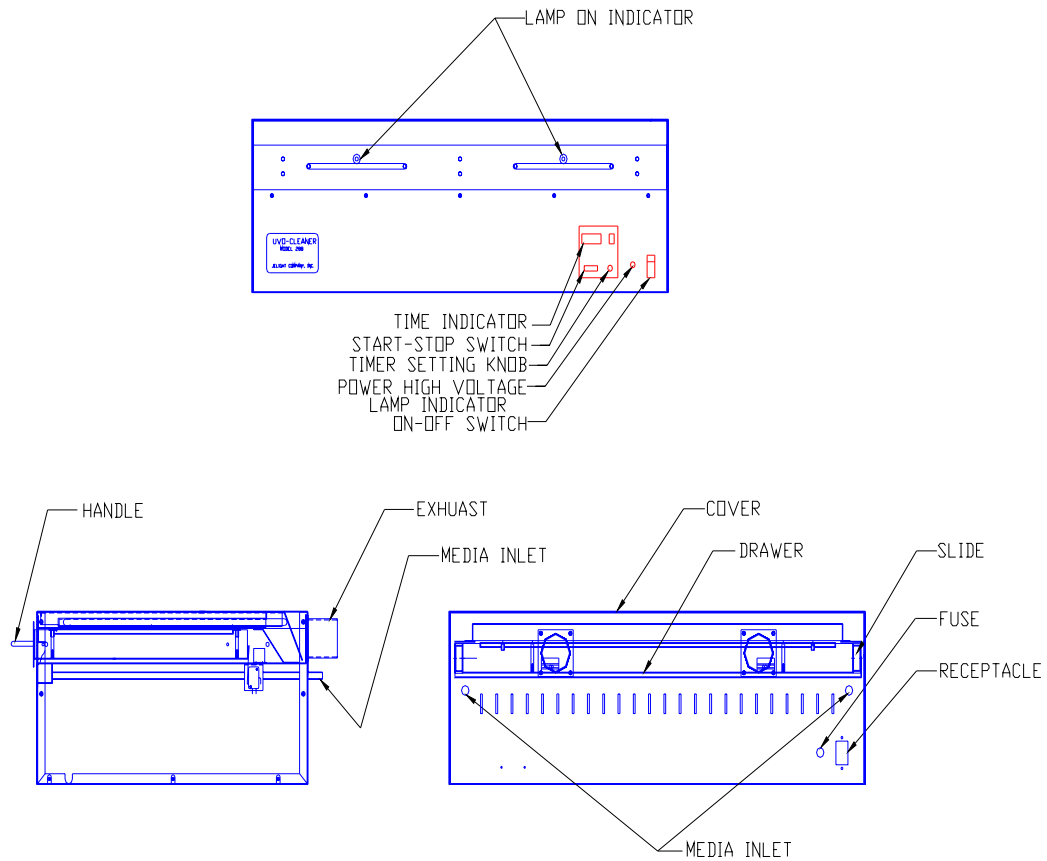

WARNING:

Potentially fatal voltages exist within this machine. Never remove the cover while the unit is plugged in to an electrical outlet. This unit produces ozone; thus, appropriate ventilation must be provided for the exhaust. Immediately deactivate the unit if ozone is detected.

The lamp in this unit emits harmful UV radiation; under no circumstances is exposure permissible. Qualified personnel must do servicing.

DESCRIPTION & ASSEMBLY

The UVO-CLEANER, Model 288 features a stainless steel cover, stainless steel drawer & base, and adjustable stainless steel cleaning tray. Two media inlets allow utilization of different gases simultaneously or in sequence.

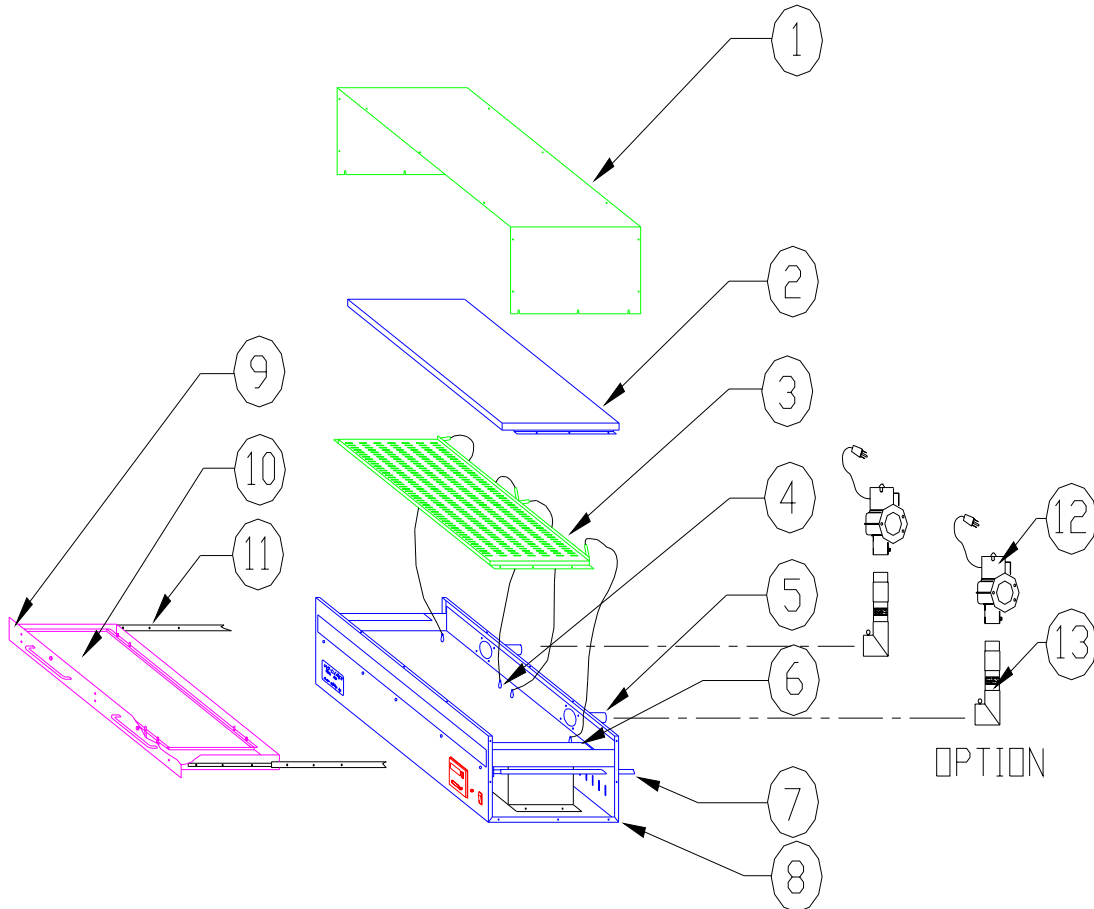

- | | | | |
|----|--------------------------|----|-------------------|
| 1 | Cover | 2 | Lamp Cover |
| 3 | Lamp Assembly | 4 | Ceramic Feed-thru |
| 5 | 2" Exhaust Port (2 pls.) | 6 | Shelf |
| 7 | Media Inlet (2 pls.) | 8 | Base |
| 9 | Drawer | 10 | Tray |
| 11 | Slide | 12 | Blower |
| 13 | Ozone Killer | | |

DESCRIPTION & ASSEMBLY (Con't)

To put the unit together, lay the lamp assembly(#3) next to the body assembly(#8) lamp side DOWN.

Connect the lamp wires(#3) to the ceramic feed-thru(#4).

Carefully place the lamp assembly(#3), lamp side DOWN, on top of the lamp bracket(#6).

Place baffle(#2)on top of the lamp assembly(#3). Screw both the lamp assembly(#3) and the baffle(#2) to the lamp bracket(#6) using the #8-32 x .30 long screws provided.

While pushing the interlock switch in, place the cover on the unit.
Secure the cover with the #8-32 screws.

OPERATION

To operate the UVO-CLEANER, Model 288, first install the lamp assembly. Refer to Description & Assembly on Page 4. Once the main power cord is plugged into an electrical outlet, the main power switch can be turned on. The switch will light indicating power to the unit.

The exhaust of the Model 288 must be attached to a suitable exhaust system capable of maintaining minus 0.1 to minus 0.5 inches of water static pressure while in operation. It is recommended that a flexible metal 2-inch duct be used to attach this unit to your exhaust system; a 2-inch PVC pipe may be substituted.

Note: The flow rate of the input media should be equal to or less than that of the exhaust in order to maintain a positive flow of the media through the system. Using a greater flow rate of the input media will cause a backpressure in the unit forcing the exhaust gases to leak into the operating environment.

Remove the cover from the media inlet ports. Should you require media other than air, use proper connectors to attach to the media inlet. Test for potential leaks. For best results, the combined maximum flow rate through the inlets should not exceed 0.5 liter per minute.

Next, load the substrate onto the removable cleaning tray. The parts must be pre-cleaned since removing large amounts of contamination will take longer periods of time. Normal cleaning times should be determined through experimentation.

Adjust the side thumbscrews on the drawer to the appropriate settings for the desired height. The actual height of the tray varies according to the height of the product being cleaned. For optimum results, the surface of the parts being cleaned should be placed approximately 5 mm away from the bottom of the lamp.

Once the drawer is shut completely, the safety interlock switch engages. If either the drawer or the cover is removed, the safety interlock mechanism automatically shuts off the UV light. Thus, accidental exposure to harmful UV radiation is prevented.

To set the cleaning time, turn the knob to the right of the display until the desired time is indicated. Push the start/stop button to activate the timer. The power indicator will light acknowledging that the lamp is receiving power, and the UV light is operating.

A clock built into the timer may be set by holding down the button with clock graphics, while turning the knob to the right of the display. It is functional when the unit is plugged in. To display the time, when the timer is not in use, press the clock button.

When the cleaning cycle is complete, the timer will sound an audible alarm and automatically extinguish the UV lamp. The drawer can then be opened, the tray removed, and the parts unloaded.

MAINTENANCE

The maintenance of the UVO-CLEANER, Model 288 requires the user to remove and clean the lamp assembly once every 100 hours of operation.

Every 5,000 to 10,000 hours of operation, the lamp assembly must be removed and replaced.

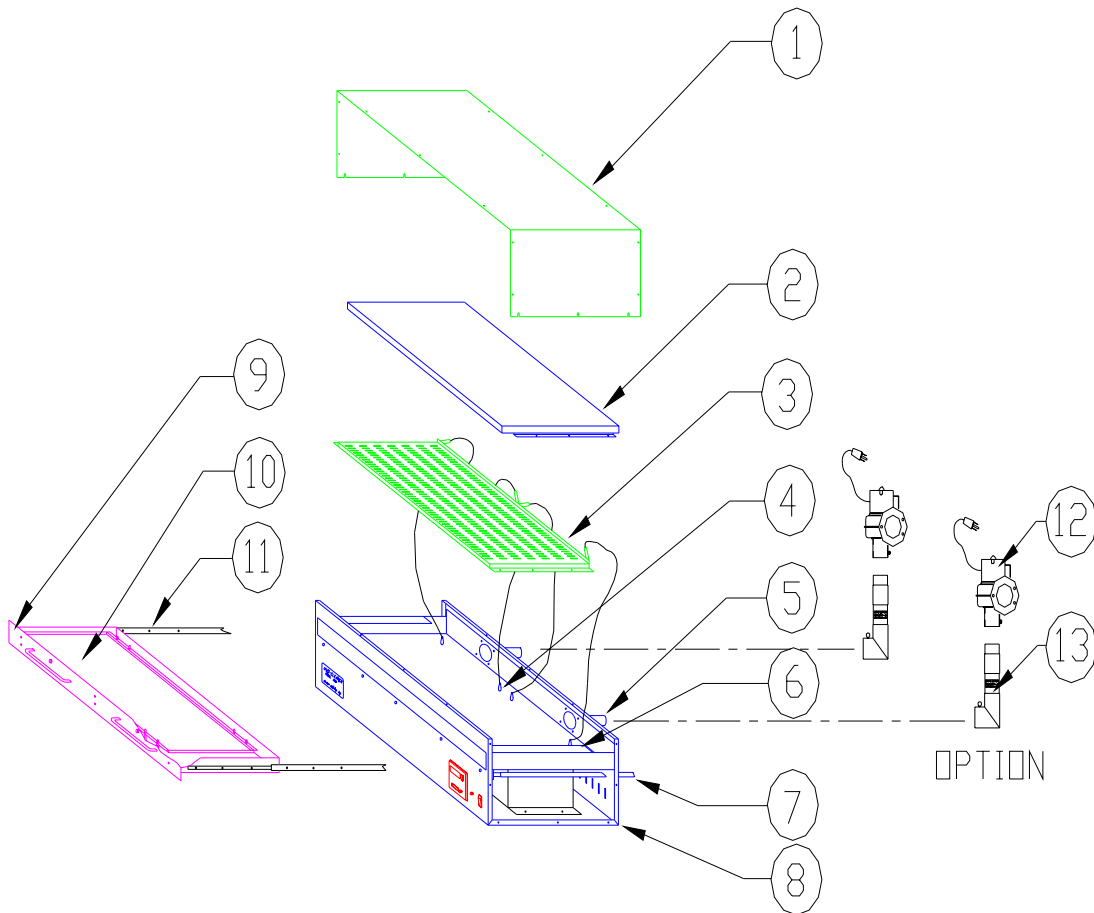

- | | | | |
|----|--------------------------|----|-------------------|
| 1 | Cover | 2 | Lamp Assembly |
| 3 | Lamp Support | 4 | Ceramic Feed-thru |
| 5 | 2" Exhaust Port (2 pls.) | 6 | Shelf |
| 7 | Media Inlet (2 pls.) | 8 | Base |
| 9 | Drawer | 10 | Tray |
| 11 | Slide | 12 | Blower |
| 13 | Ozone Killer | | |

TROUBLE SHOOTING

SYMPTOM: No Power To The Unit.

Check the power receptacle.

Check the fuse.

Check the cover & drawer interlock mechanism.

SYMPTOM: Power To The Unit But Timer Does Not Function.

Check the power source.

Check the drawer interlock mechanism.

SYMPTOM: UV Indicator Does Not Light.

Check power indicator lamp.

Replace the UV lamp assembly.

If this does not solve the problem, contact the factory.

SYMPTOM: Ozone Is Present Outside Of The Unit During Operation.

Check the exhaust connections.

Check the exhaust the unit is attached to.

SPECIFICATIONS

Size (Max.) 23.0" Long X 28.5" Wide X 9.5" High

Power Requirements 110 Volts, 60 Hz., 10 Amps

Lamp Type Low Pressure Mercury Vapor Grid

Lamp Output . . 28,000 Micro Watts Per Cm⁵ @ 254 Nm
(From 6mm Dist.)

Tray Size. 12" X 24" Ozone Cleaning Area

