

CHIPhERASER®

MODEL 356

INSTRUCTION MANUAL

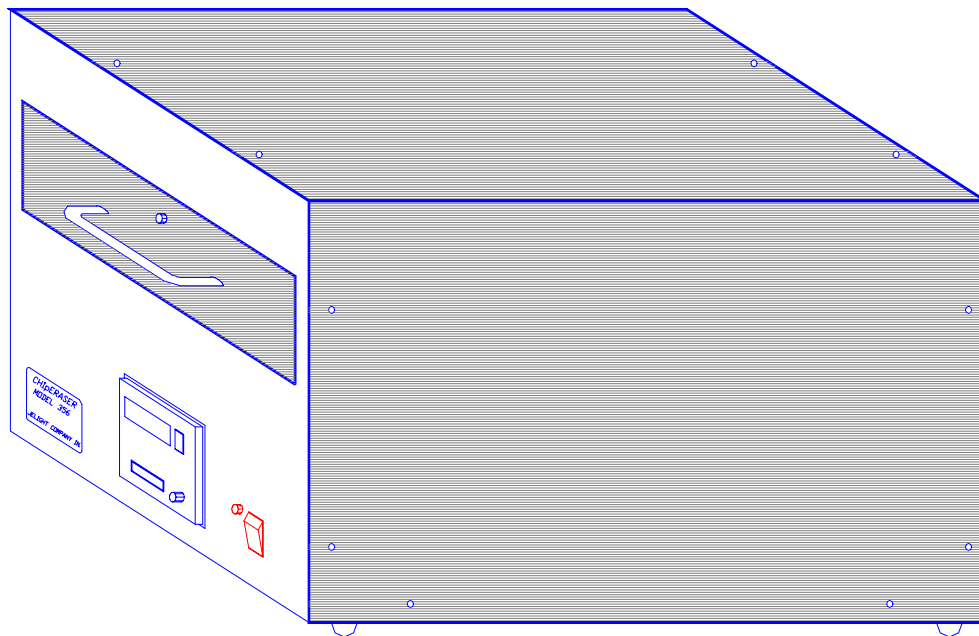

JELIGHT COMPANY, INC.

2 Mason

Irvine, CA 92618 U.S.A.

Tel: (949)380-8774 Fax: (949)768-9457

E-mail: sales@jelight.com

TABLE OF CONTENTS

1. Introduction	2
2. Description	3
3. Operation	4
4. Maintenance	5
5. Troubleshooting	6
6. Specifications	7
7. Schematic	8

INTRODUCTION

The Model 356 CHIPhERASER⁷ is a rugged, large capacity unit designed to provide many years of trouble-free service. The Model 356 contains a low-pressure mercury vapor grid lamp, which produces higher UV intensity than most competitive systems, allowing for greater efficiency in EPROM erasing.

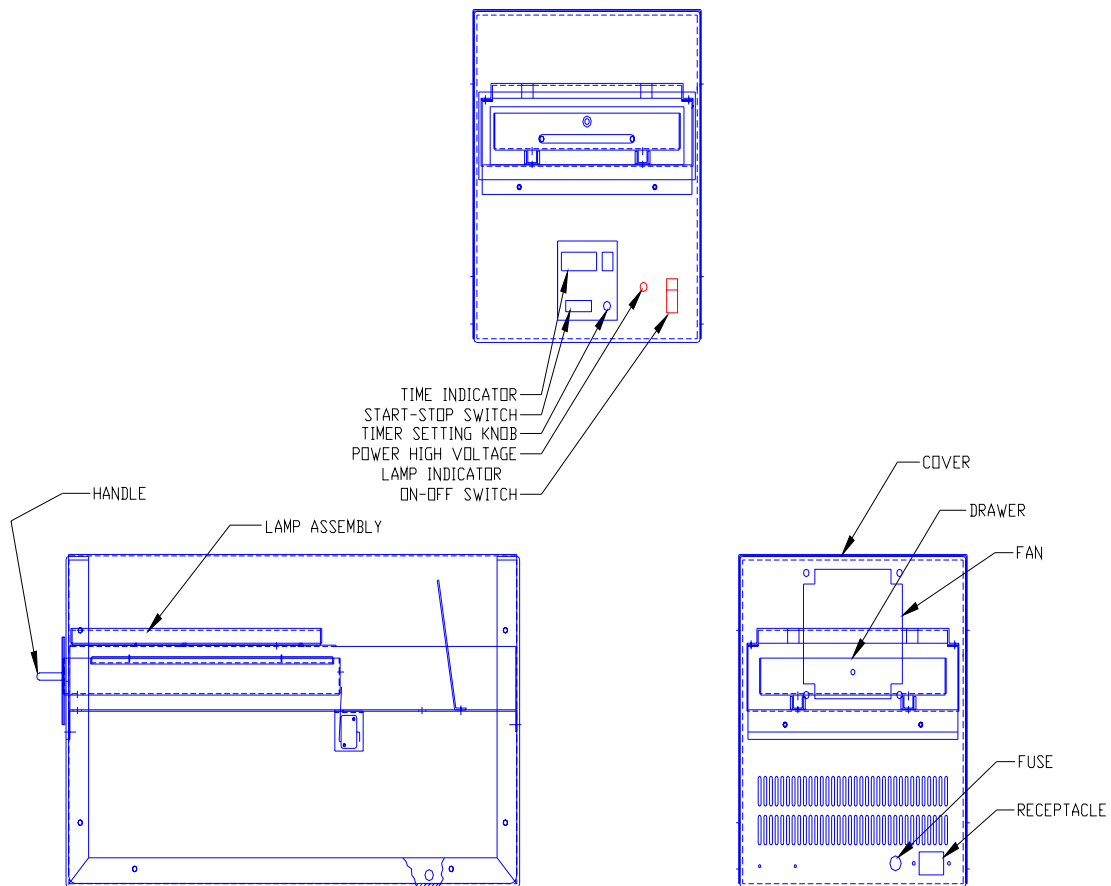

WARNING:

Potentially fatal voltages exist within this machine. Never remove the cover while the unit is plugged into an electrical outlet.

The lamp in this unit emits harmful UV radiation; under no circumstances should the user be exposed to the UV radiation. Qualified personnel must do servicing of this unit only.

DESCRIPTION

The Model 356 CHIPHERASER⁷ has a stainless steel cover, stainless steel drawer, adjustable stainless steel product tray and heavy-duty aluminum powder coated base.

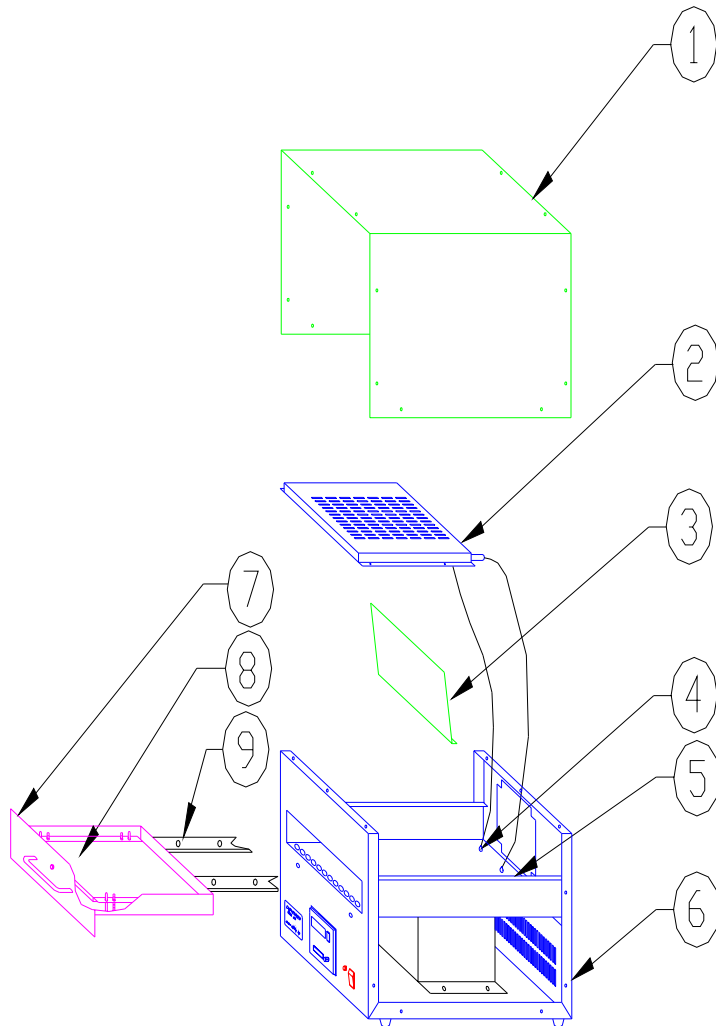

- 1 Cover
- 3 Air Baffle
- 5 Shelf
- 7 Drawer
- 9 Slides

- 2 Lamp Assembly
- 4 Ceramic Feed-thru
- 6 Base
- 8 Tray

OPERATION

LAMP INSTALLATION: See lamp installation instructions under maintenance.

After installing the lamp in the unit the first step to operate the Model 356 is install a main power cord and plug it to the appropriate receptacle. The main power switch can then be turned on. At this time, the switch will light and the exhaust fan will start. This indicates there is power to the unit.

The next step is to load EPROMs on the removable tray. The tray is provided with a conductive pad. The EPROMs are pressed into the pad. After the tray is loaded, install the tray in the drawer of the unit. The tray is installed over the guide pins in the drawer and the tray height is adjusted. There are four 8-32 knob screws provided with the tray to set the height. The actual height of the tray will be determined by testing EPROMs after they have been erased. For minimum erasing time, the tray height should be set so that the tray is closest to the UV source.

To set the erasing time, turn the knob to the right of the display until the desired time is displayed. The start/stop button is pushed to start the timer. The timer is a solid state count down timer. The power indicator will light. This indicates power is received by the lamp power supply. The lamp will light and is visible through the UV indicator.

If the unit is to remain plugged in, a clock built into the timer may be set by holding the button with the clock graphics down and turning the knob to the right of the display. To display the time when the timer is not in use, press the clock button.

When the cycle is complete, the timer will sound an audible alarm and turn the lamp off. The drawer can be opened, tray removed, and parts unloaded. The timer need not be reset unless a different process time is necessary.

The drawer and cover are safety interlocked. If either are opened or removed the lamp will shut off. This prevents accidental exposure to harmful UV radiation.

MAINTENANCE

The only maintenance is to vacuum the rear vents once a week to remove dust and other contaminants. Every 5,000 to 10,000 hours of operation, the lamp assembly must be replaced. **Use extreme CAUTION not to break the lamps.**

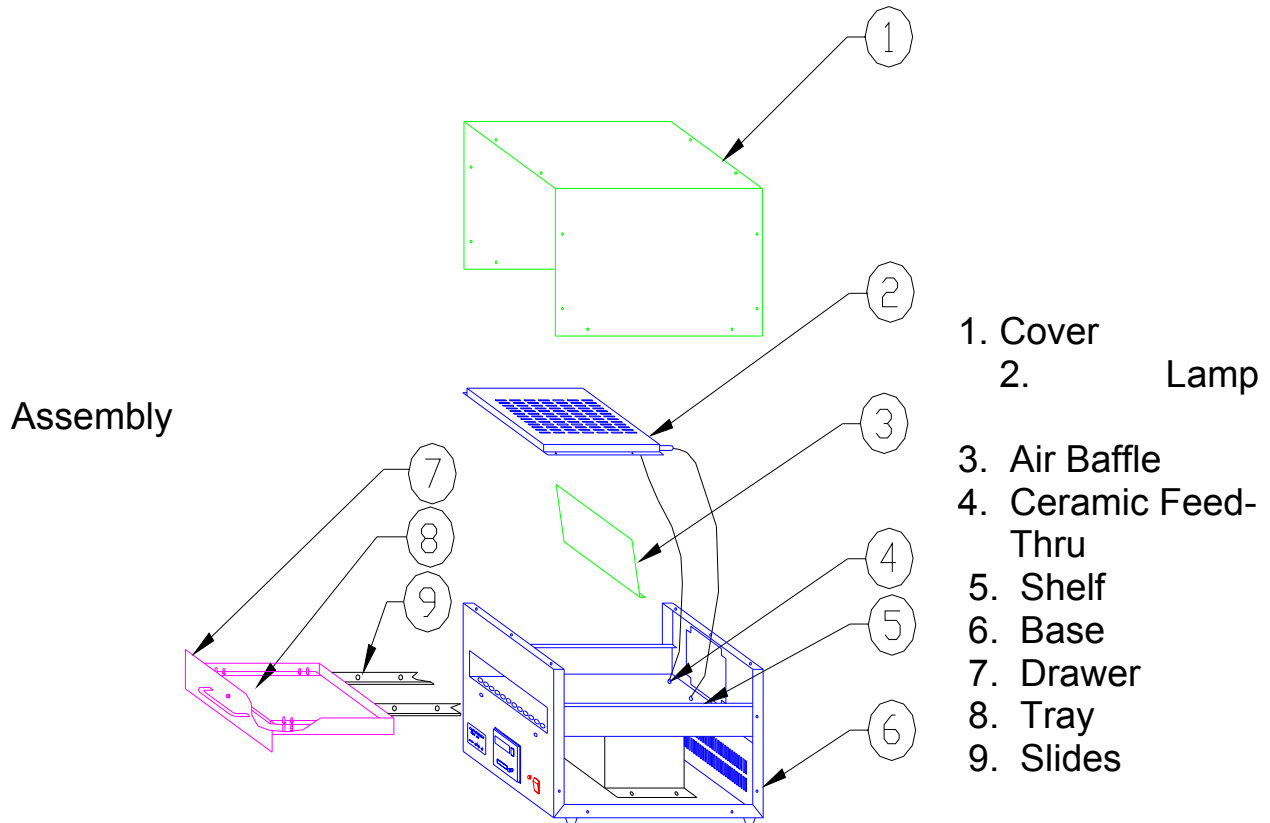

To change the lamp assembly, disconnect the main power cord. Remove the screws retaining the cover, and carefully lift off the cover(1). Remove the two screws retaining the rear baffle(3). Carefully remove the rear baffle. Remove the two nuts at the high voltage insulators(4). Use care and do not rotate the remainder of the threaded rod that passes through the ceramic insulators. Remove the four screws attaching the lamp assembly to the shelf(5). Return the lamp assembly to the factory for disposal or dispose the lamp per state laws.

To install the new lamp assembly, attach it to the shelf with four screws. Attach the leads to the insulators using the nuts previously removed. Use care and do not rotate the threaded rods extending through the ceramic insulators. Install the rear baffle(3) using two screws. Install the cover(1), making sure that the interlock switch is under the cover, using the screws previously removed. Connect the main power cord to the unit and verify its operation.

TROUBLESHOOTING

SYMPTOM: NO POWER TO UNIT

Check power receptacle.
Check fuse.
Check cover interlock switch.

SYMPTOM: POWER TO UNIT, TIMER DOES NOT FUNCTION

Check drawer interlock switch.

SYMPTOM: POWER TO UNIT, TIMER FUNCTIONS, UV INDICATOR DOES NOT LIGHT.

Check power indicator lamp is lit.
Check lamp assembly.
If this does not solve problem return unit to factory.

SPECIFICATIONS

SIZE(Max)	102 " W x 22" L x 12" H
POWER REQUIREMENTS	120 VOLTS, 60 HZ., 7 AMPS
LAMP TYPE	LOW PRESSURE MERCURY VAPOR GRID LAMP
LAMP OUTPUT	50,000 MICRO WATTS PER CM ⁵ @ 1"(From 6mm Dist.)
DRAWER SIZE	8" W x 11" L x 13" D
TRAY SIZE	6 : " W x 102 " L

