

CHIPhERASER⁷

MODEL 2436

INSTRUCTION MANUAL

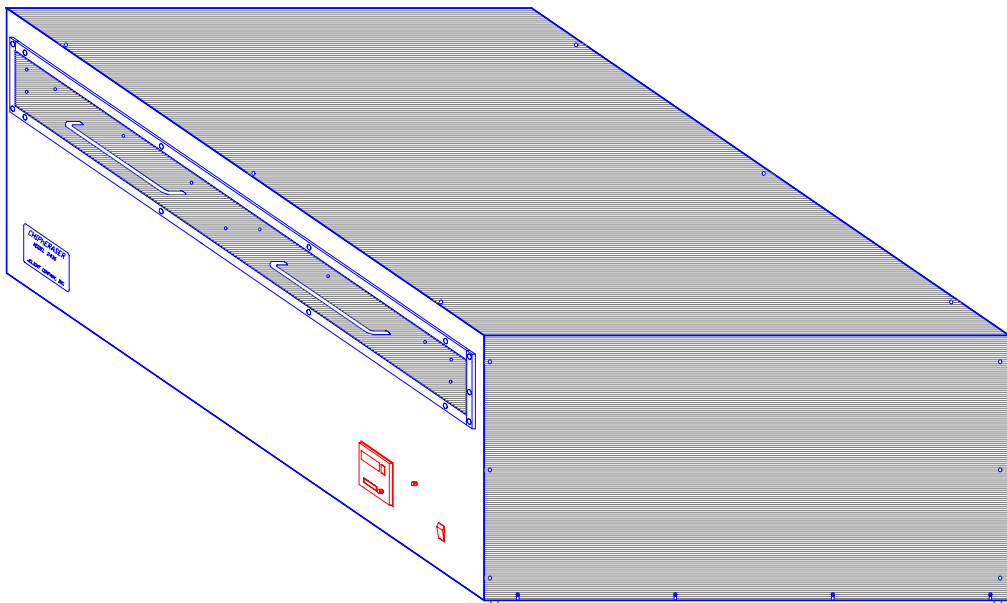

JELIGHT COMPANY, INC.

2 Mason

Irvine, CA 92618 U.S.A

Tel: (949)380-8774

Fax: (949)768-9457

E-mail: sales@jelight.com

CHIPhERASER⁷

MODEL 2436

TABLE OF CONTENTS

INTRODUCTION	2
DESCRIPTION	3
OPERATION	4
MAINTENANCE	5
TROUBLESHOOTING	6
SPECIFICATIONS	7
SCHEMATIC	8

INTRODUCTION

The CHIPhERASER, Model 2436, is a rugged, large capacity unit designed to provide many years of trouble-free service. The 2436, utilizes low-pressure mercury vapor grid lamps which produce higher intensities than most competitive systems, allowing for greater efficiency in production.

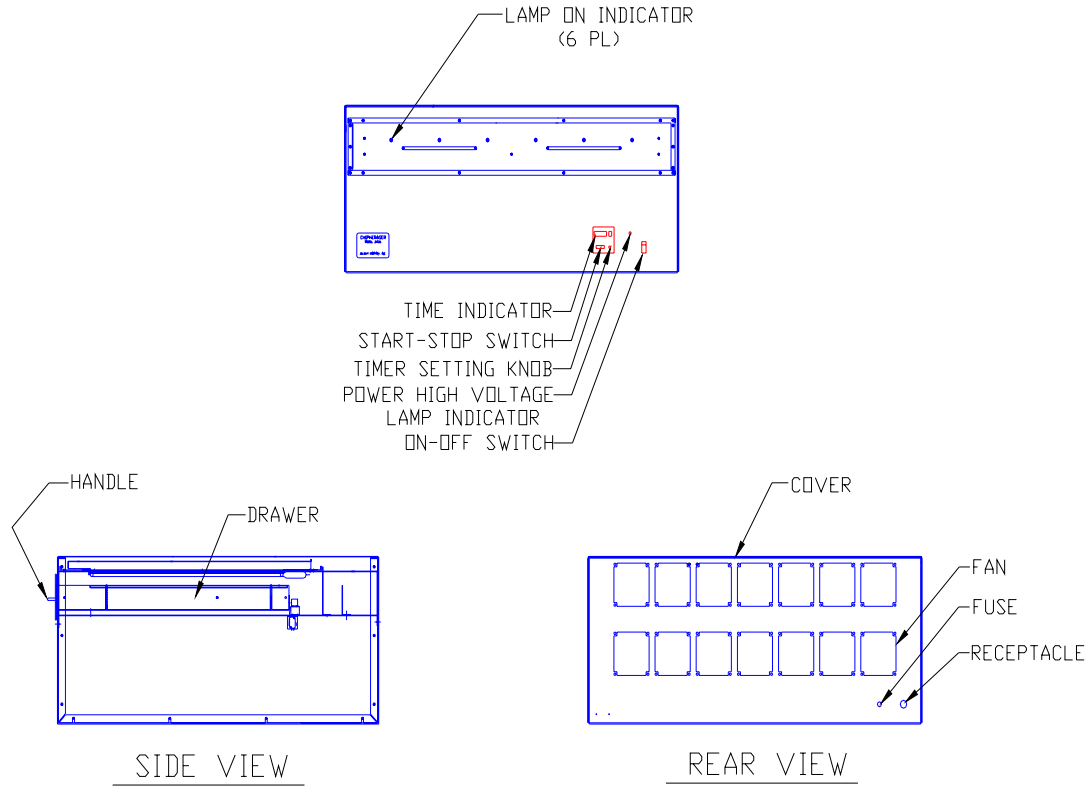

WARNING:

Potentially fatal voltages exist within this machine. Never remove the cover while the main power cord is plugged into an electrical outlet.

The lamp in this unit emits harmful UV radiation; under no circumstances should the user expose himself/herself to the UV source.

DESCRIPTION

The Model 2436 is equipped with a heavy-duty aluminum powder coated base, stainless steel cover, stainless steel drawer, and adjustable stainless steel product tray.

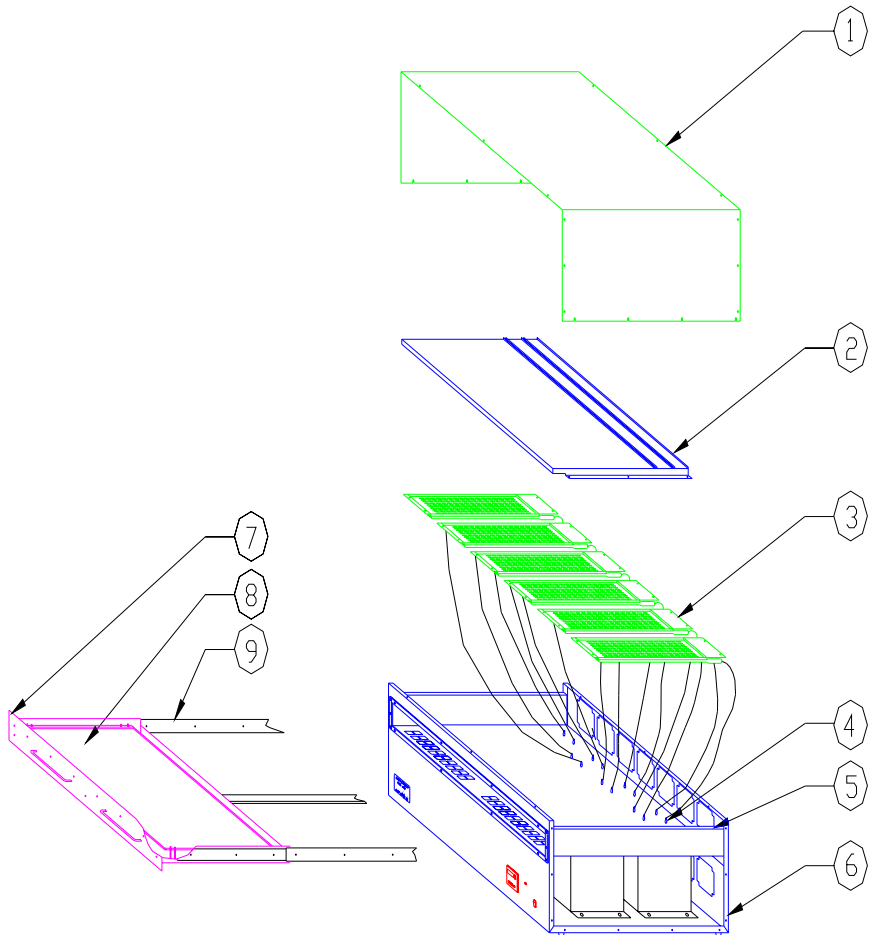

- | | | | | | |
|----------|--------------------------|----------|---------------|----------|--------------|
| 1 | Cover | 5 | Shelf | 9 | Slide |
| 2 | Lamp Cover | 6 | Base | | |
| 3 | Lamp support | 7 | Drawer | | |
| 4 | Ceramic Feed-thru | 8 | Tray | | |

OPERATION

To operate the Model 2436, first plug the power cord into the appropriate receptacle. The main power switch can then be turned on. At this time, the switch will light and the bottom row of fans will activate; indicating power to the unit.

Next, load the wafers/EPROMS onto the removable tray. After the tray is loaded, push the drawer of the unit closed. The magnetic catch provides resistance to insure that the drawer of the unit remains closed throughout operation.

The removable tray is installed over guide pins in the drawer, which enable the user to adjust the height of the tray. Use the guide pins to set and adjust the height of the tray. The actual height of the tray should be determined by testing for optimum uniformity of UV.

To set the erasing time, turn the knob to the right of the display until the desired time is shown. Push the start/stop button to activate the timer. The power indicator will light, acknowledging that power is received by the lamp power supplies. The lamps will light, and will be visible through the UV indicator. After a period of two minutes, the upper row of fans will automatically turn on. This time delay is adjustable, and varies from 0 - 10 minutes. To change the time delay, remove the cover and adjust the setting located on the right hand side of the base.

A clock built into the timer may be utilized when the power is left on. To set the clock, hold the button with the clock graphics down while turning the knob to the right of the display. To display the time, when the timer is not in use, press the clock button.

When the cycle is complete, the timer will sound an audible alarm and automatically extinguish the lamps. The drawer can then be opened, the tray removed, and the parts unloaded. The timer need not be reset unless a different process time is necessary.

To prevent accidental exposure to harmful UV radiation, the cover and the drawer are safety interlocked. If either are opened or removed during operation, the lamps will automatically extinguish.

MAINTENANCE - USE EXTREME CAUTION!!!

For optimum results, replace the lamp assemblies every 5,000 to 10,000 hours of operation.

To install new lamp assemblies, use extreme CAUTION not to break the lamps. Disconnect the main power cord. Remove the cover, then remove the lamp screws. Loosen the top portion of the feed-thru screws. Insert the lamp on the lamp back holder in such a way that the electrodes go below the lamp holder, and the lamp reflector goes above the lamp holder. Tighten the screws to secure the lamp assemblies in place. Attach the lamp connector to the appropriate feed-thru.

To change the lamp assemblies, disconnect the main power cord. Remove the screws retaining the cover, and carefully lift off. Next, loosen the top portion of the feed-thru screws. Disconnect the lamp connectors from the feed-thrus. Remove the screws that secure the lamp assemblies in place. Carefully lift the lamp assemblies out, using caution not to break off the electrodes.

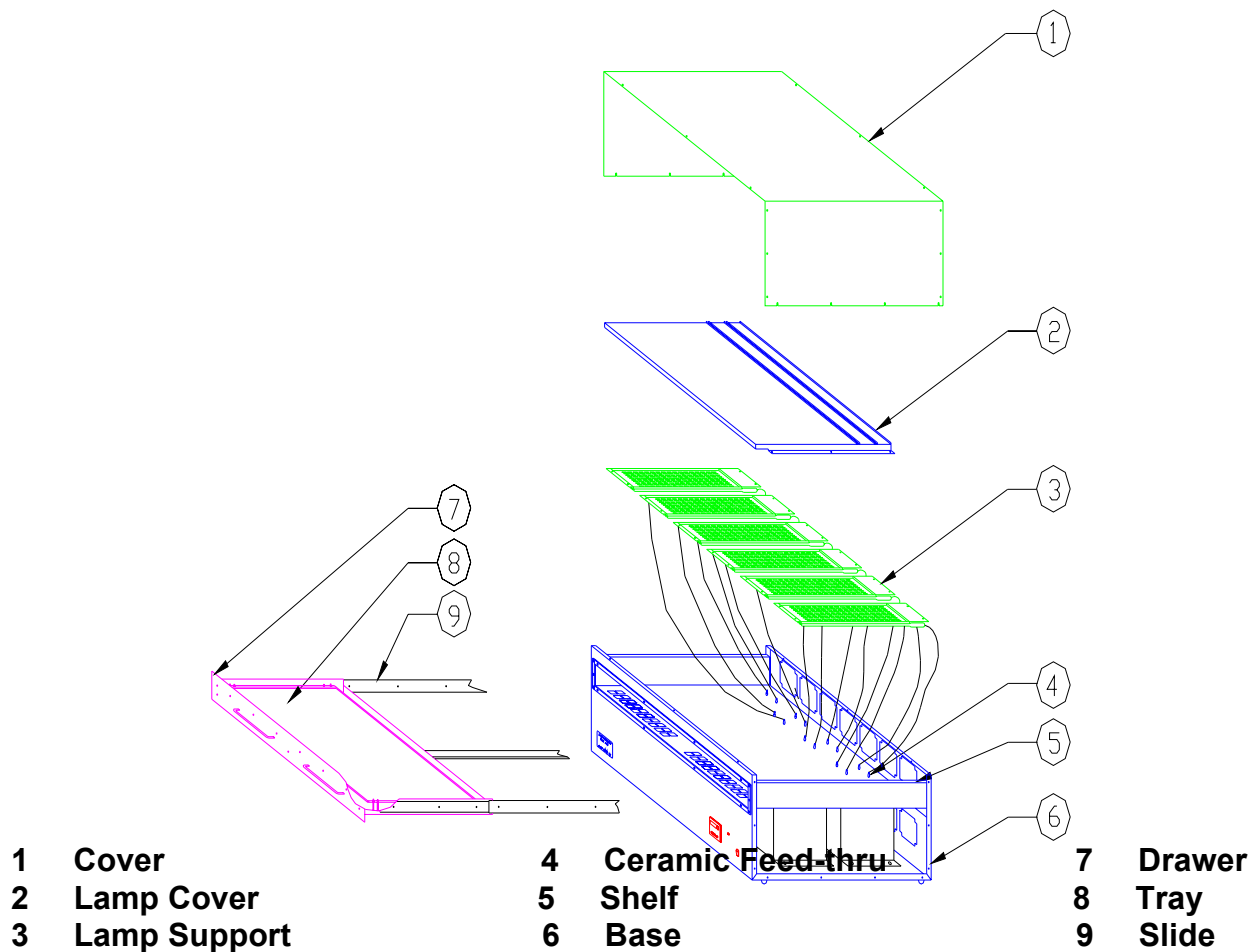

TROUBLESHOOTING

SYMPTOM: No Power To The Unit.

Check main power fuse = 3 amps.

(Refer to Figure 1)

Check power supply fuse = 5 amps.

(Refer to Figure 1)

Check cover interlock switch.

(Refer to Figure 1)

SYMPTOM: Timer Does Not Function With Power To The Unit.

Check drawer interlock switch.

(Refer to Figure 2)

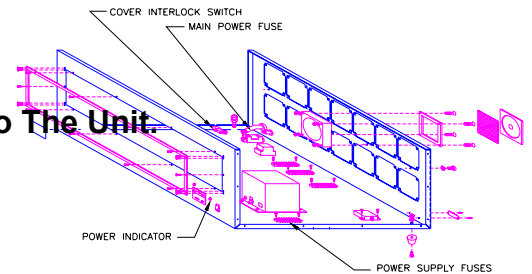

FIGURE 1

SYMPTOM: Timer Functions, But UV Indicator Does Not Light.

Make sure the power indicator lamp is on.

Replace lamp assemblies.

If this does not solve problem, return unit to factory.

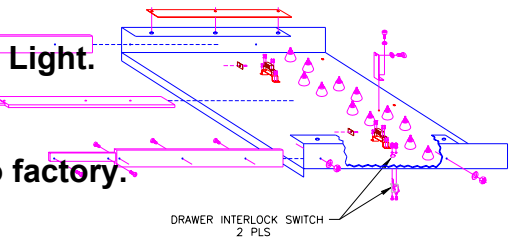

FIGURE 2

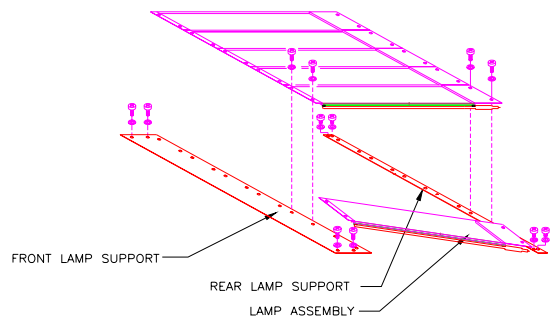

FIGURE 3

SPECIFICATIONS

Size(Max)	42" Long, 17.50" High, 42" Wide
Power Requirements	220 Volts, 60 Hz, 30 Amps
Lamp	Low Pressure Mercury Vapor Grids
Lamp Output	50,000 Micro Watts Per Sq. Cm. @ 1" (From 6mm Dist)
Drawer Size	38.5" x 29" x 2.5" Deep
Tray Size	24" x 36" Erasing Area

